

Formulate Designer Series 20' Backwall - Kit 03

FMLT-DS-20-03

Formulate® Designer Series 20ft displays have unique stylistic features and shapes, are portable and easy to assemble. The aluminum tube frame features snap-buttons and/ or spigot connections and zipper pillowcase fabric graphics. All displays come in portable, wheeled transit cases. Simply pull the pillowcase fabric graphic(s) over the frame and zip.



features and benefits:

- Premium aluminum tube frames with snap button/ spigot assembly
- Easy to store and ship
- Quick to set up
- Weighted feet for added stability
- Two zipper pillowcase fabric graphics
- Lifetime limited hardware warranty against manufacturer defects

dimensions:

Hardware

Assembled unit:
227" w x 96" h x 40.75" d
5766mm(w) x 2438mm(h) x 1035mm(d)

Approximate weight:
170 lbs / 77.1 kgs

Shipping

Packing case(s):
3 OCE Case

Shipping dimensions:
OCE: Expandable case length (l) may vary
40" - 66" l x 18" h x 18" d
1016mm-1677mm(l) x 458mm(h) x 458mm(d)

Approximate total shipping weight
(includes cases & graphics):
202 lbs / 92 kgs

Graphic

Refer to related graphic template for more information.

Visit:
www.exhibitors-handbook.com/graphic-templates

additional information:

Graphic material:
dye-sublimation zipper pillowcase fabric

We are continually improving and modifying our product range and reserve the right to vary the specifications without prior notice. All dimensions and weights quoted are approximate and we accept no responsibility for variance. E&OE. See Graphic Templates for graphic bleed specifications.

Included In Your Kit

Tools, Components, & Connectors



ALLEN KEY SET x1



ES30 x36

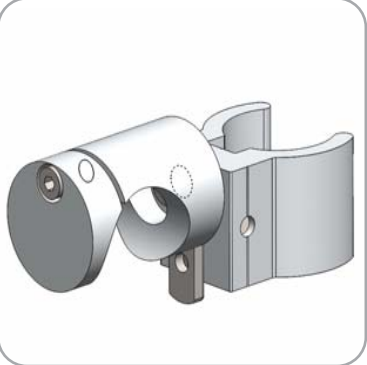

TC-30-TCH-30-ASY x2



TC-30-S x1



PLT-BP-LN114-S2-450 x4



LN114-SCREW x4

Graphics

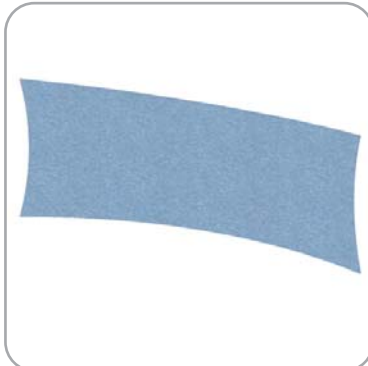

DS-20-03-A-G x1



DS-20-03-B-G x1

Included In Your Kit

Tubes

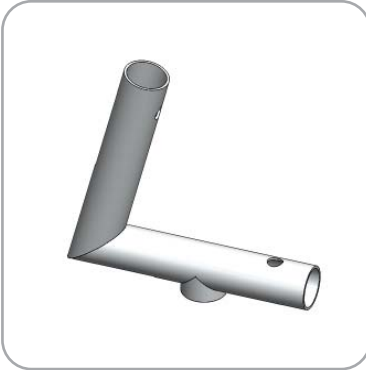

DS-20-03-T1 x2



DS-20-03-T2 x2



DS-20-03-T3 x1



DS-20-03-T4 x1



DS-20-03-T5 x4



DS-20-03-T6 x8



DS-20-03-T7 x1

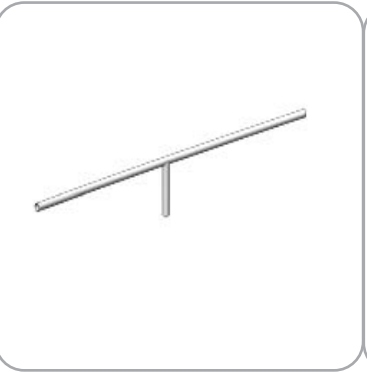

DS-20-03-T8 x1



DS-20-03-T9 x1



DS-20-03-T10 x1



DS-20-03-T11 x2



DS-20-03-T12 x1

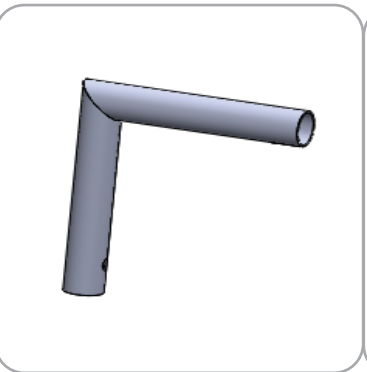

DS-20-03-T13 x1

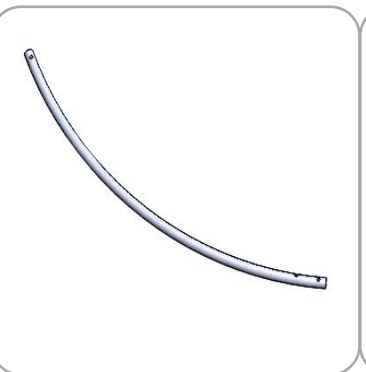

DS-20-03-T14 x1

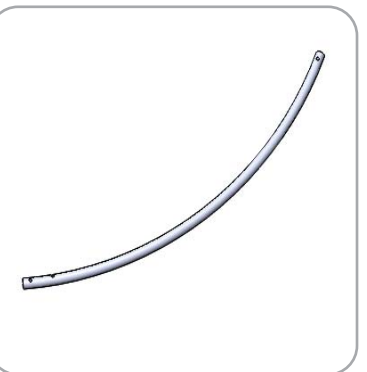

DS-20-03-T15 x1

Included In Your Kit

Tubes



DS-20-03-T16 x4

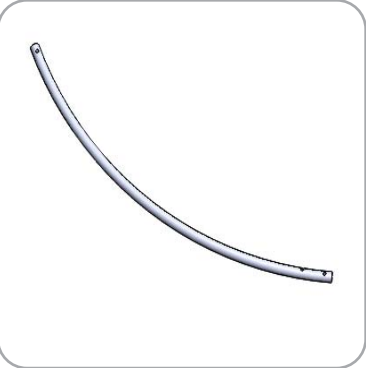

DS-20-03-T17 x1

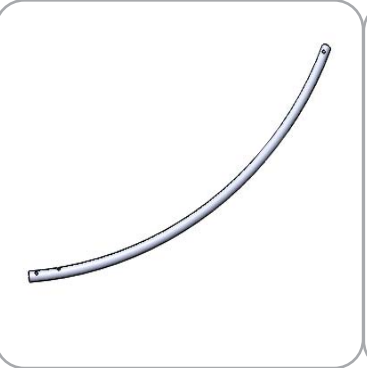

DS-20-03-T18 x1

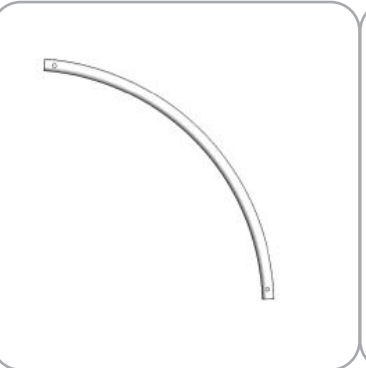

DS-20-03-T19 x2



DS-20-03-T20 x1

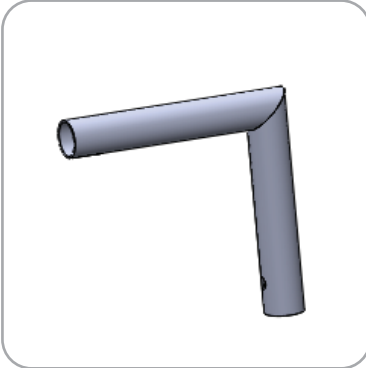

DS-20-03-T21 x1

Exploded View

FMLT-DS-20-03

FRAME A

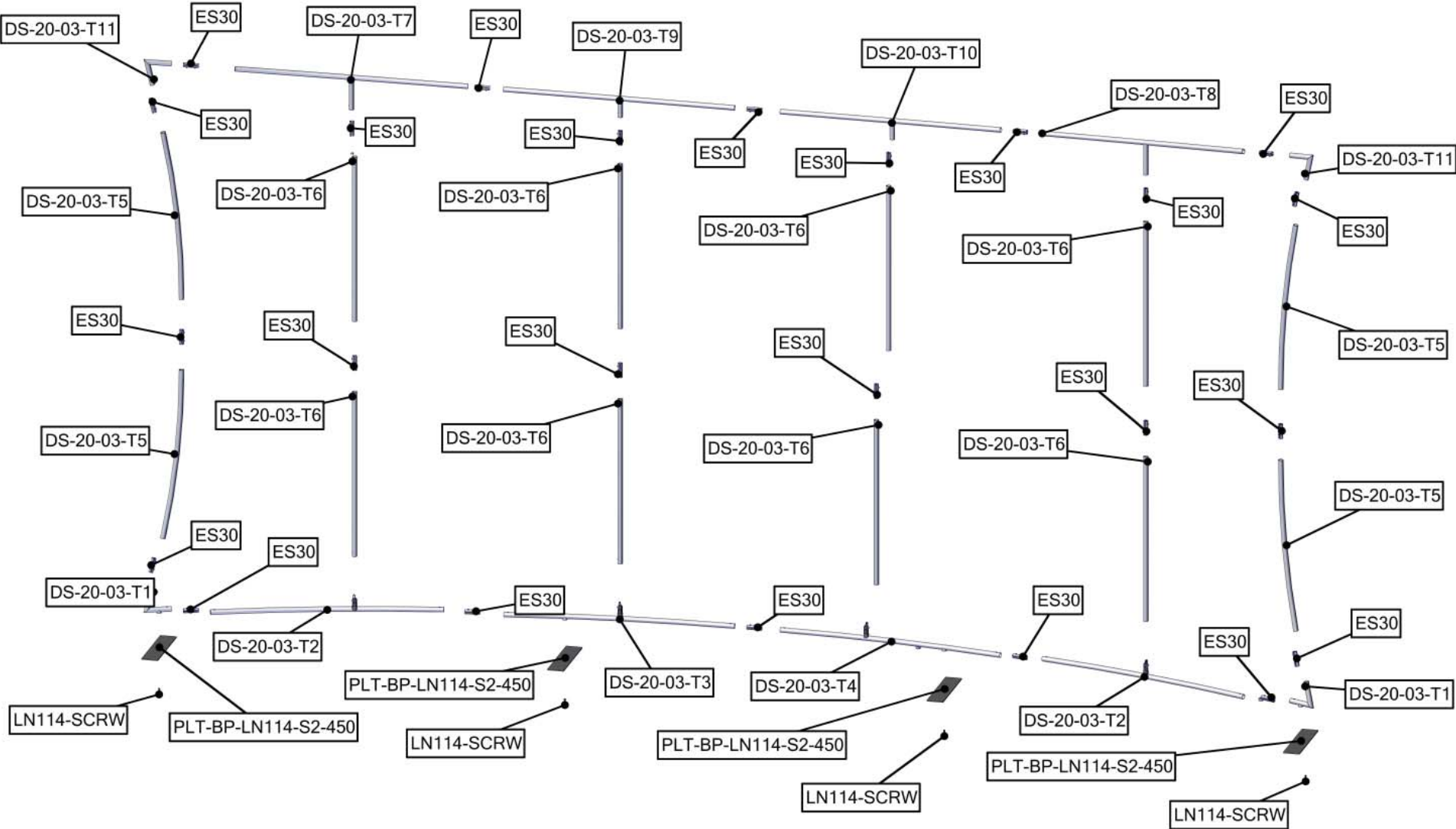

Exploded View

FMLT-DS-20-03

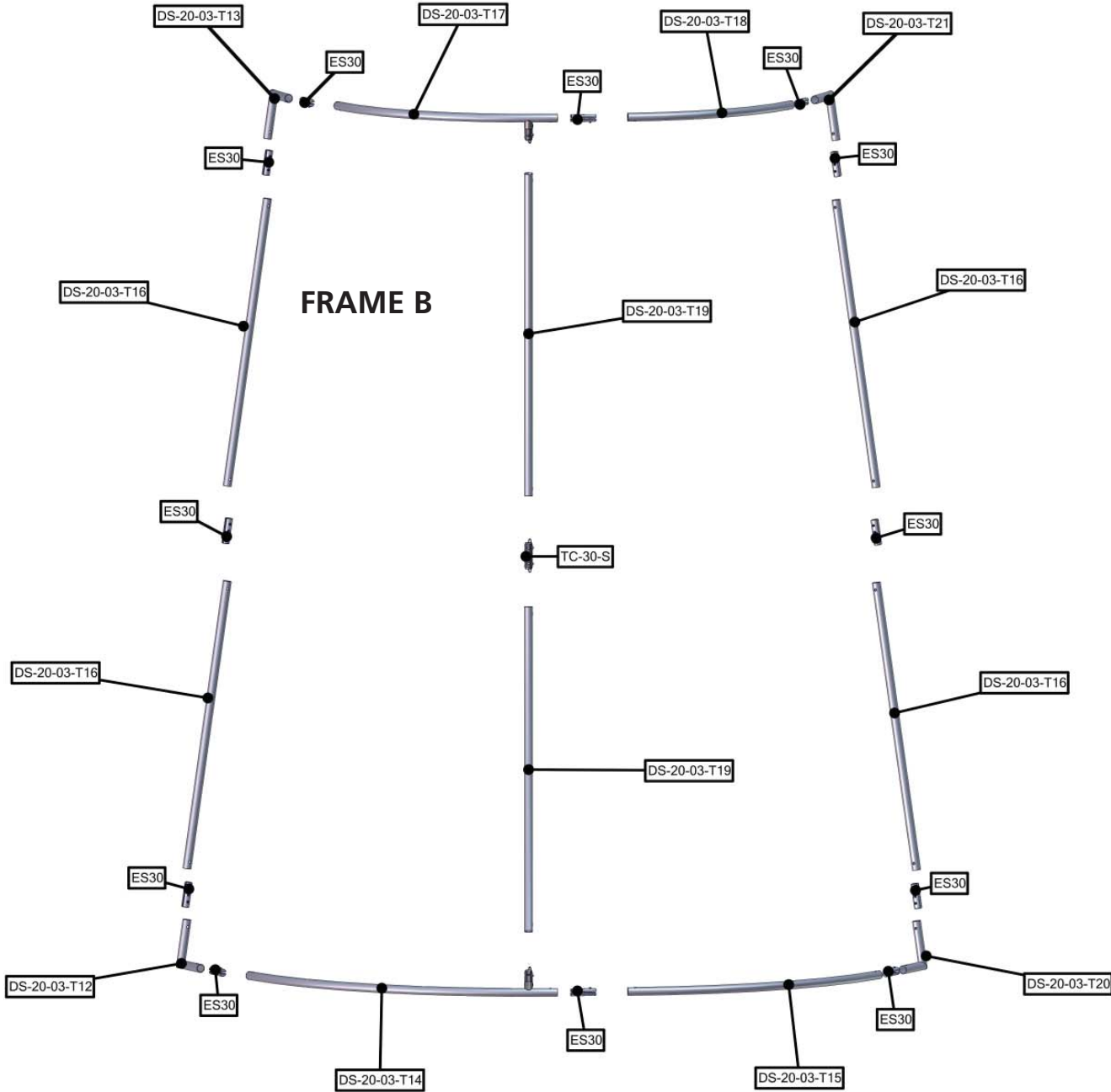

Labeling Diagram

FMLT-DS-20-03

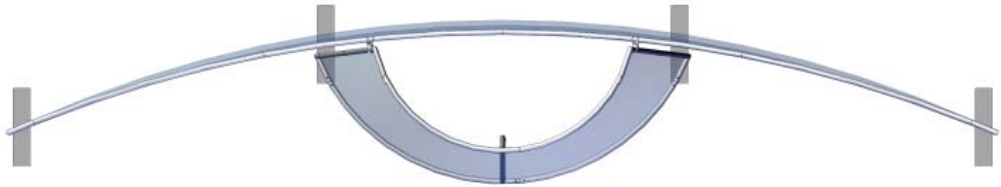
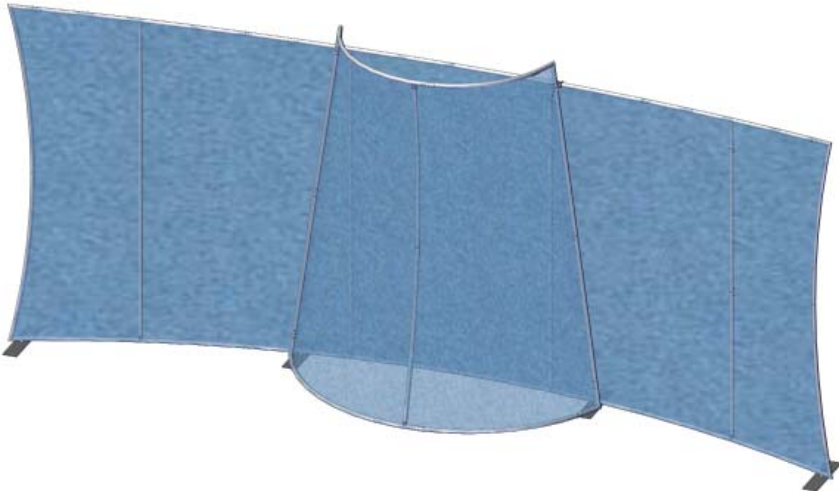
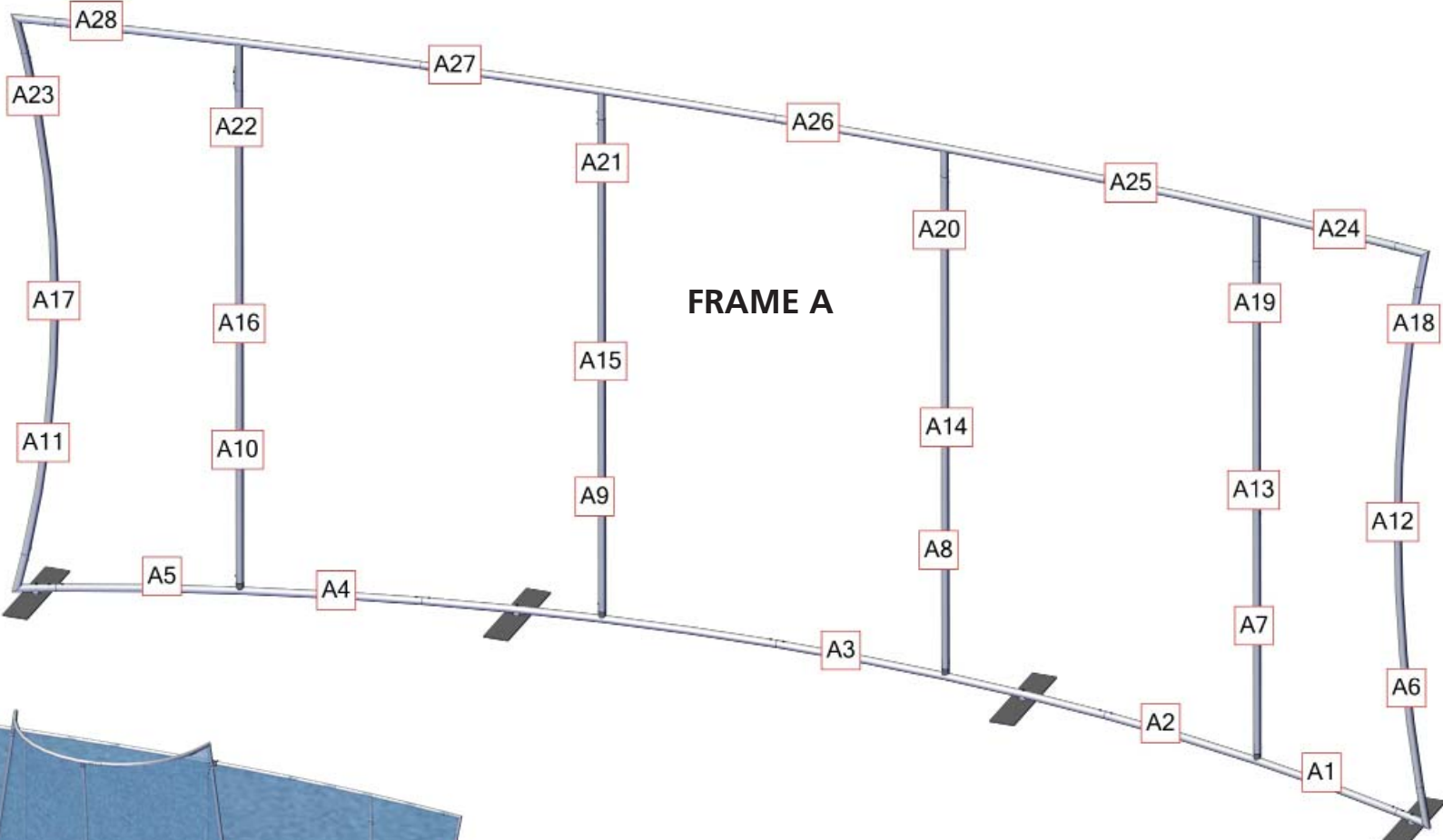

OVERVIEW

Labeling Diagram

FMLT-DS-20-03

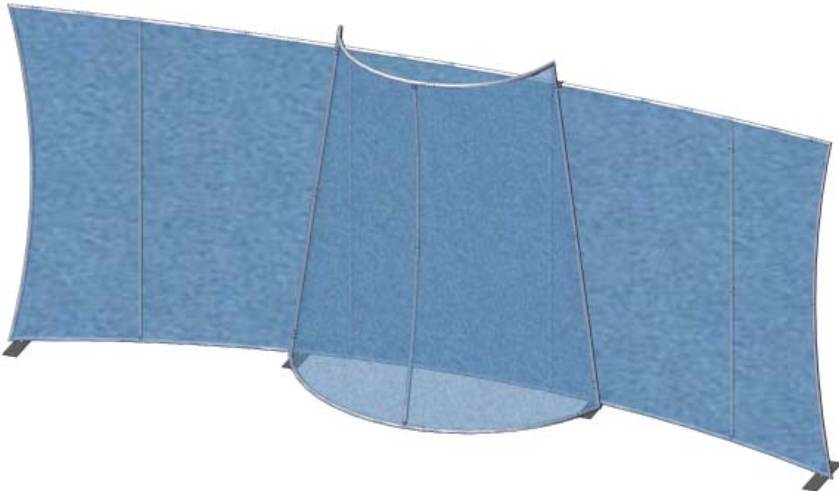

OVERVIEW

Connection Methods

Formulate™ structures use a number of different yet simple connection methods. Your kit will include one or more of the connection methods shown below. Steps within the Kit Assembly will reference a specific method for each connection point.

Connection Method 1: ES30 / ES50 / ES75

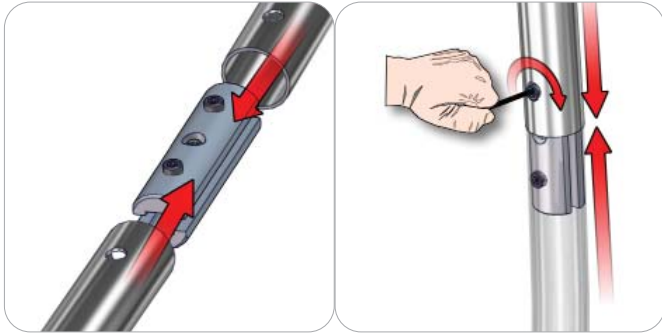

Compress the unlocked connector and slide one tube onto each end. Lock both screws carefully using your allen key tool. Be sure to lock securely, but do not overtighten.

Connection Method 2: Snap Buttons & Swage

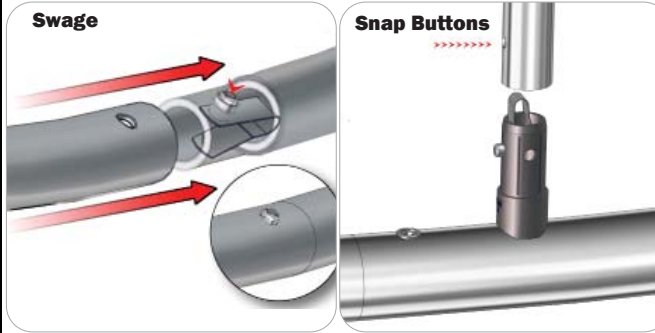

Locate the snap button on the connector or swage tube. Locate the hole on the corresponding tube. Press the snap button with your thumb and slide the tube and connector together so that the snap button snaps fully into the lock hole. To disassemble, press the snap button and pull apart.

Connection Method 3: ES30-90B / ES30-I / ES30-C

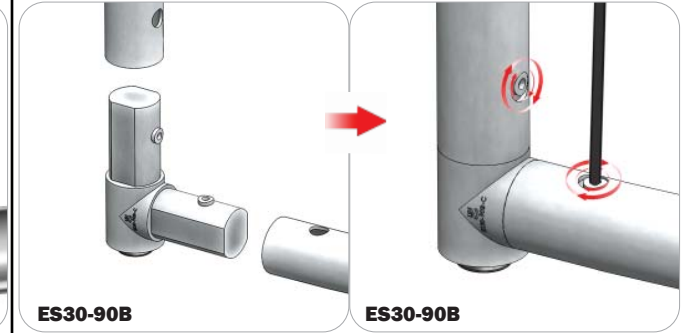

Compress one unlocked end of the connector and slide it through one tube end. Compress the other end of the connector and slide the second tube on. Lock both screws carefully using your allen key tool. Be sure to lock securely, but do not overtighten.

Connection Method 4: Tube Clamps

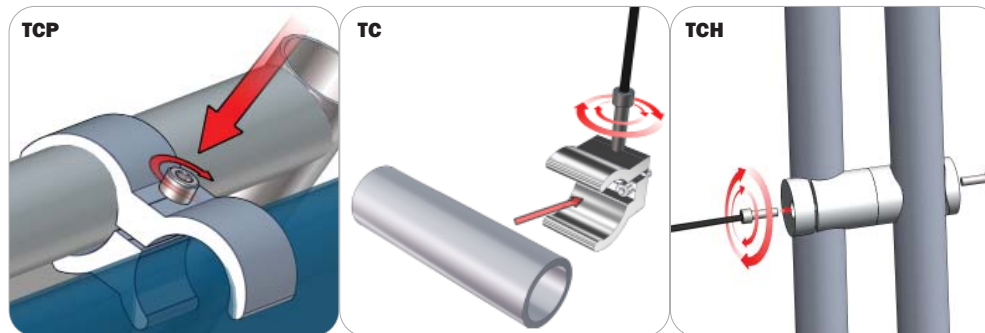

Be sure to fully assemble all frames before using clamps. With the clamp unlocked, place one tube of the first frame into the mouth of the clamp. Place the second tube (if applicable) into the second mouth of the clamp. With both frame's tubes in the clamp, be sure to lock securely, but do not overtighten.

Kit Assembly

Step by Step

Step 1.

Locate the components necessary for assembling Frame A. Assemble your frame in order according to the Labeling Diagram.

Please reference Connection Method 1 for more details.

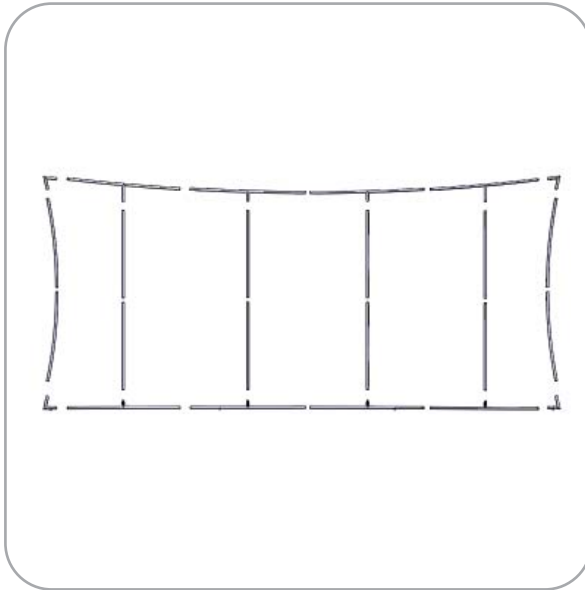
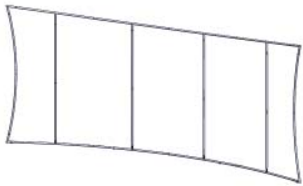

Step 3.

Fit graphic A onto Frame A. For ease of installation, pull the fabric cover over the top of the frame while the frame rests flat on the floor. Zip to enclose.

Zipper located to the bottom of Graphic B

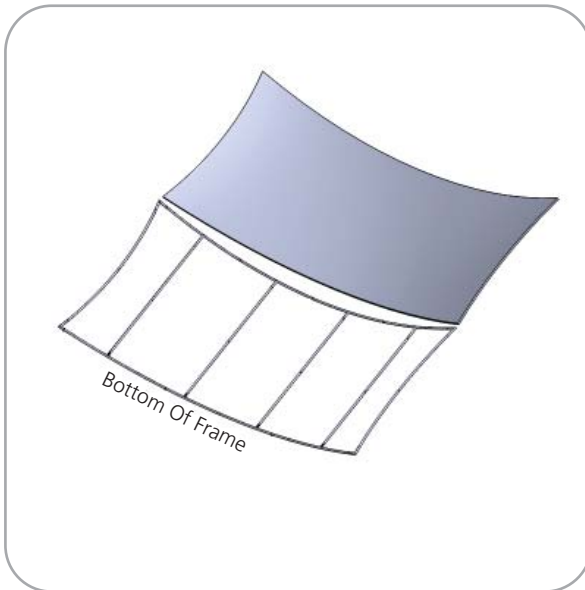

Step 2.

Locate the components necessary for assembling Frame B. Assemble your frame in order according to the Labeling Diagram.

Please reference Connection Methods 1 and 2 for more details.



Step 4.

Fit graphic B onto Frame B. For ease of installation, pull the fabric cover over the top of the frame while the frame rests flat on the floor. Zip to enclose.

Zipper located to the bottom of Graphic B

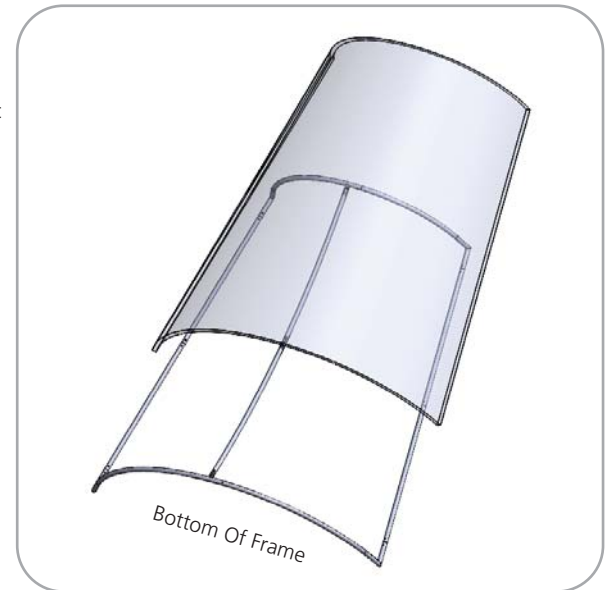

Kit Assembly

Step by Step

Step 5.

Gather two PLT-BP-LN114-S2-450's, and two LN114 screws. Attach the foot to the left and right sides of Frame B.



Step 6.

Combine the Frames A and B with the two TC-30-TCH-30-ASY clamps. With the clamps loosened, connect Frame A and B, then tighten in place using the provided allen key tool.

Please reference Connection Method 4 for more details.

